



Test report is for reference only.

TEST REPORT
for
JXWBGF-T-3-10-1000-B16

Technical Specification

| | |
|----------------------------------|--------------------|
| Frequency Range(MHz) | 10-1000 |
| Insertion Loss(dB) | L: 0.3/0.8 Typ/Max |
| | M: 0.3/0.8 Typ/Max |
| | U: 0.8/1.2 Typ/Max |
| Isolation(dB) | L: 25/15 Typ/Min |
| | M: 30/20 Typ/Min |
| | U: 35/24 Typ/Min |
| Phase Unbalance(°) | 4 max |
| Amplitude Unbalance(dB) | 0.5 max |
| Connector | BNC-Female |
| Operating Temperature(°C) | -40 ~ +80 |
| Storage Temperature(°C) | -55 ~ +85 |

Outline Drawing (Size: mm)

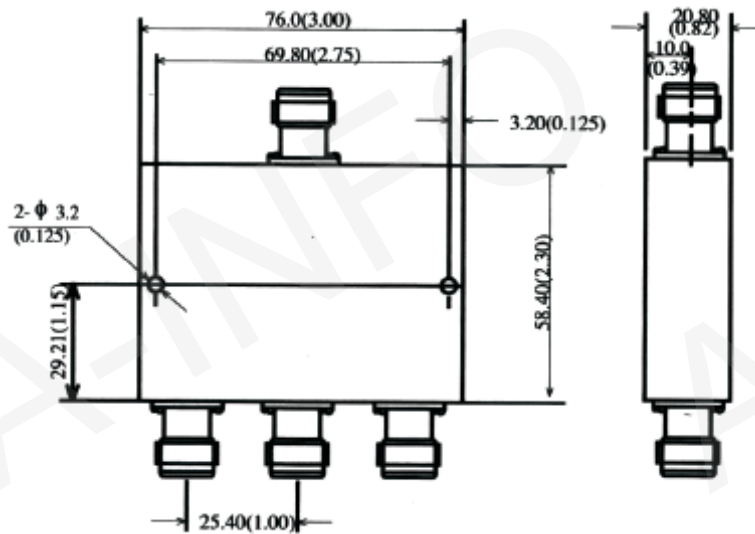

Test Results

1. Insertion Loss

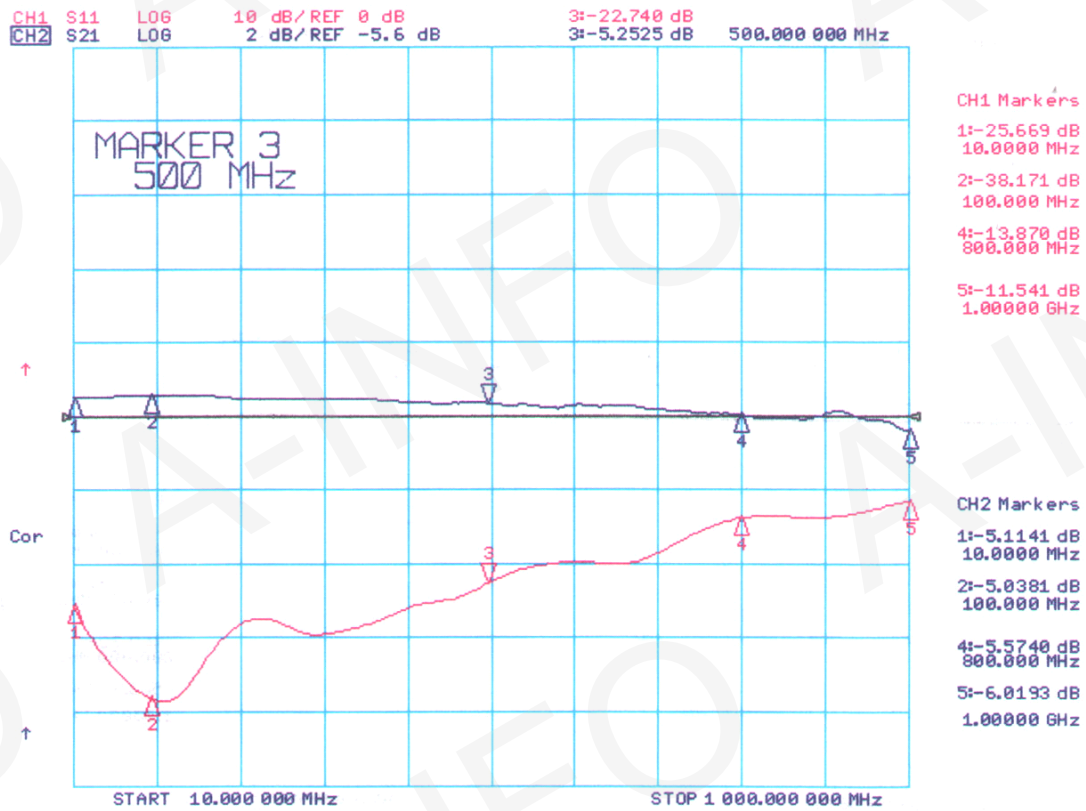

2. Isolation

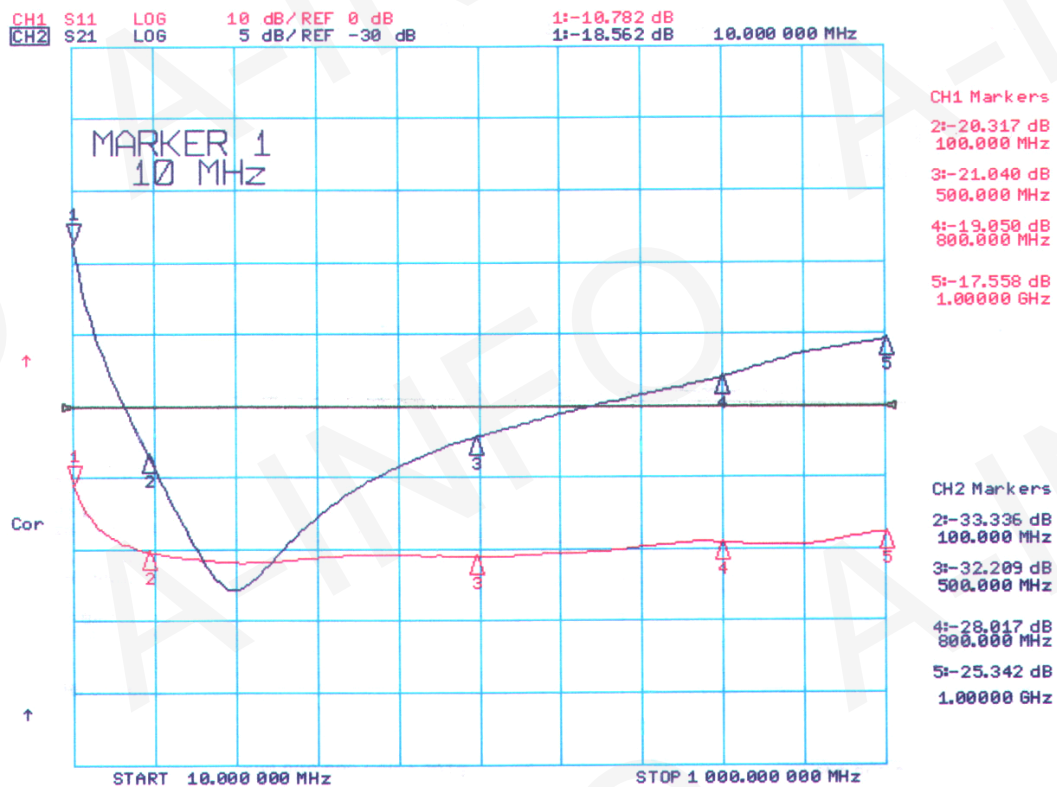

3. Phase Unbalance

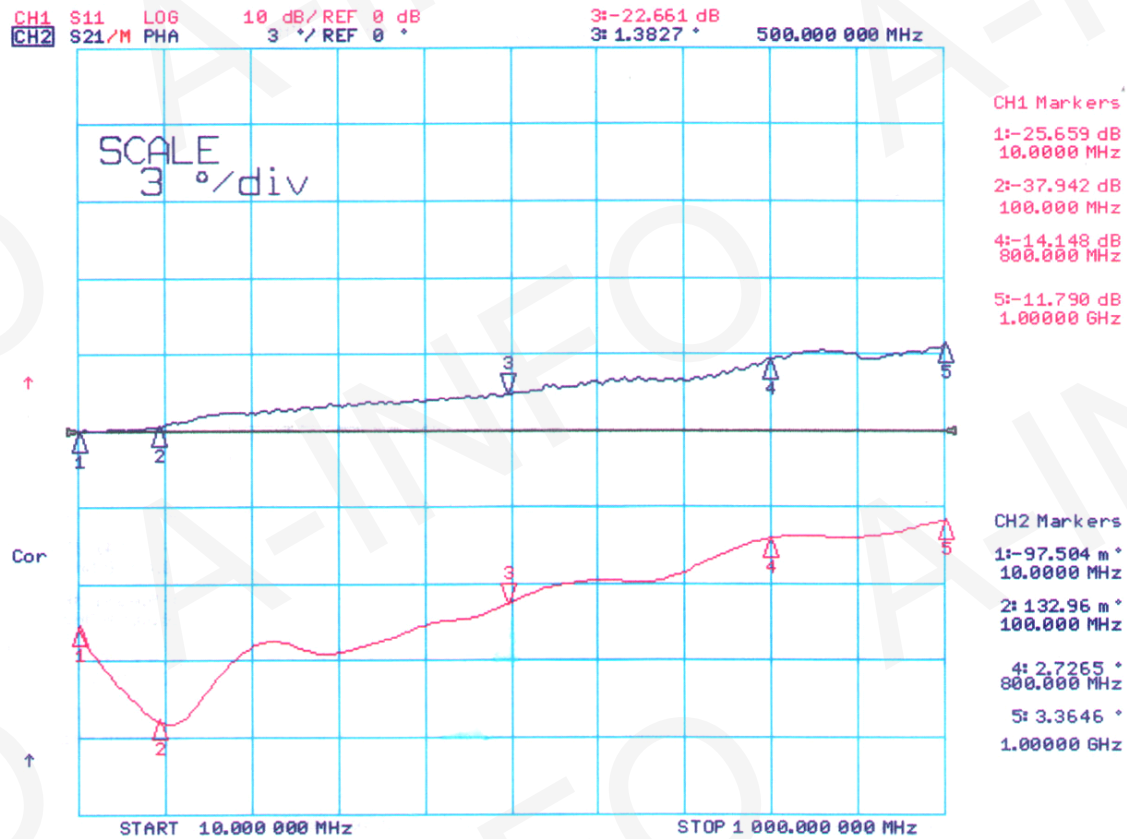

4. Amplitude Unbalance

