



Test report is for reference only.

TEST REPORT
For
JXWBLA-T-10-500-35

Technical Specification

Frequency Range(MHz)	10-500
Gain(dB)	35
Pout@1dB(dBm)	+17
Noise Figure(dB)	2.0
Input VSWR	1.7
Output VSWR	1.7
Power Supply(V/mA)	+12/120
Connector	SMA-Female
Operating Temperature(°C)	-40 ~ +70
Storage Temperature(°C)	-55 ~ +80
Size(mm)	60 x 32 x 22

Outline Drawing (Size: mm)

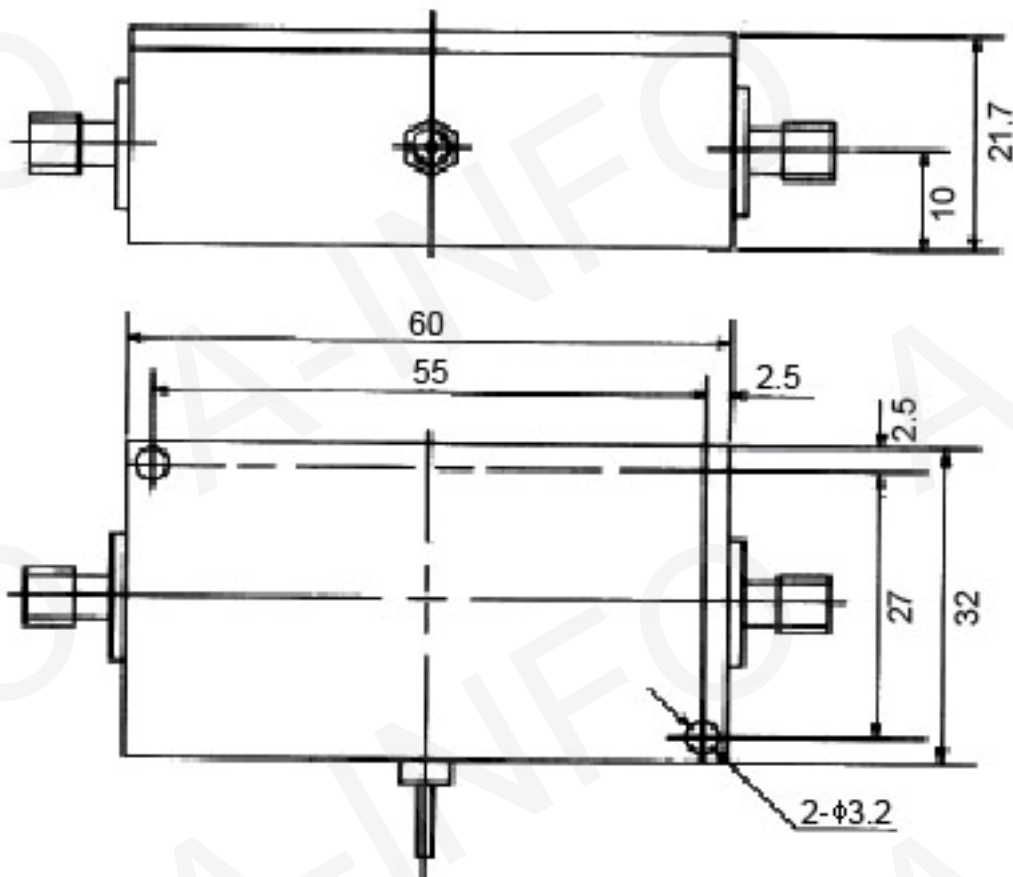

Test Results

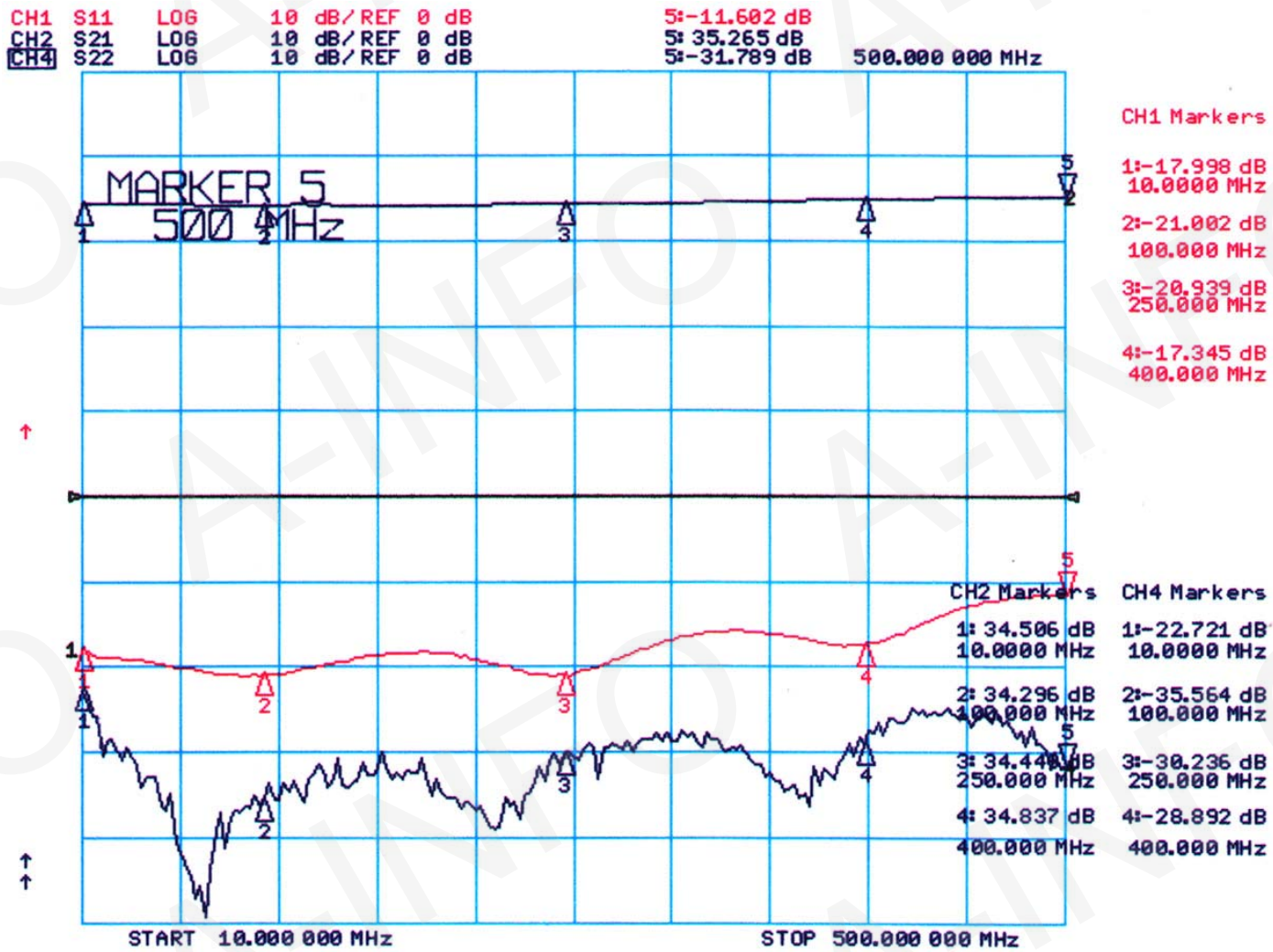

CH1: Input VSWR
 CH2: Gain
 CH4: Output VSWR